

Important information
Please read

english



C Y P R E S

User's Guide

Congratulations on your choice of CYPRES, the safest and most accurate AAD currently available. CYPRES is the only completely electronic automatic opener on the market, as well as the smallest and the lightest.

Like most skydivers, you probably assume you will always have time to deploy your reserve canopy yourself, and that situations requiring use of an automatic opener always happen to others. We do hope that you will never have such trouble, and that your CYPRES will never have to take action to save your life.

Should CYPRES ever have to open your reserve, it will most probably happen at a moment which justifies, no matter how experienced and cautious you are, that you haven't left your safety to chance.

Airtec GmbH, Safety Systems

Dieses Handbuch ist in deutsch erhältlich.

Ce manuel est disponible en français.

Dit Handboek is ook in het Nederlands verkrijgbaar.

Este manual está disponível em Português.

Este manual está disponible en español.

Questo manuale è disponibile in italiano.

Ez a kézikönyv magyar nyelven kapható. (Hungarian)

Tento manual je k dostání v češtině. (Czech)

Ta instrukcja jest dostępna w języku polskim.

Ýòó èíèã- ììèàíèý ìíæí ìíèó-èòù ìà ðóííèì ÿçúèå. (Russian)

Contents

	page
1. Function	3
1.1 Design philosophy	3
1.2 Components	4
1.3 How CYPRES works	5,6
1.4 Energy supply	7
1.5 Operational safety	8
2. Product Overview	9
2.1 Expert CYPRES	9
2.2 Student CYPRES	10
2.3 Tandem CYPRES	10
3. Installation	11
3.1 Processing unit	12
3.2 Release unit	13
3.3 Control unit	14,15,16
4. How to Operate CYPRES	17
4.1 Handling the control unit	17
4.2 Switching CYPRES on	18,19
4.3 When to switch on or off	20
4.4 Changing altitude reference	21,22
4.5 Water jumps	23
5. Errors Display	24
6. Maintenance	25
6.1 Removal of the unit	25
6.2 Replacing battery	26,27,28,29
6.3 Changing the release unit	30
6.4 Technical service	31
7. Important Notes	32
7.1 For jump pilots	32
7.2 For users	33
8. Repacking of Reserves	34,35
8.1 Packing one-pin reserve containers	36,37
8.2 Packing two-pin reserve containers	38
8.3 Packing one-pin Pop Top reserve containers	39
8.4 Packing two-pin Pop Top reserve containers	40-45
8.4.1 Additional notes to the Racer and Racer Elite	46
9. Abbreviated Users' Guide	47
10. Installation in a New Rig	48
11. Regarding Air Travel	49
12. Technical Data	50
13. Guarantee	51
14. Electromagnetic Compatibility	52
15. Disclaimer	53
16. Key Words	54,55
17. Packing list	56
Trade Marks	57

1. Function

1.1 Design philosophy

CYPRES, which is the acronym of "**CY**bernetic **P**arachute **R**Elease **S**ystem", is an automatic activation device, which meets all needs and wishes of today's skydivers. Once it is installed, you can't hear it, you can't feel it and you can't see it.

The operation is quite simple: Just switch it on in the morning prior to the first jump, then forget about it. It is not necessary to switch it off, because CYPRES will do this itself.

The weather is constantly checked by CYPRES over the day by measuring the air pressure twice a minute. This means that the unit is always calibrated to the precise ground level.

The Expert CYPRES is designed in a way that it won't restrict the skydiver in any way. Even with extreme maneuvers during exit and in freefall, CYPRES will cope with it. Whatever you can think of under canopy like stalls, spiral turns, down planes, hookturns with the smallest canopies as well as any CRW, CYPRES will analyze these movements without problems. It won't interfere with any normal activities while skydiving.

Only freefall in very low altitude will cause CYPRES to take action. In this situation CYPRES will activate the reserve approx. 4.5 seconds prior to impact.

Besides the Expert CYPRES there are the Tandem and Student CYPRES. These models meet the special requirements of tandem jumps and student training.

From January 1991 to February 2001, CYPRES has saved at least 240 skydivers and 12 tandem students.

1.2 Components

CYPRES consists of a microprocessor-based, self-checking processing unit, a control unit through which prejump altitude adjustments are made, and a release unit (EOS). Two release units are used on dual-pin systems.

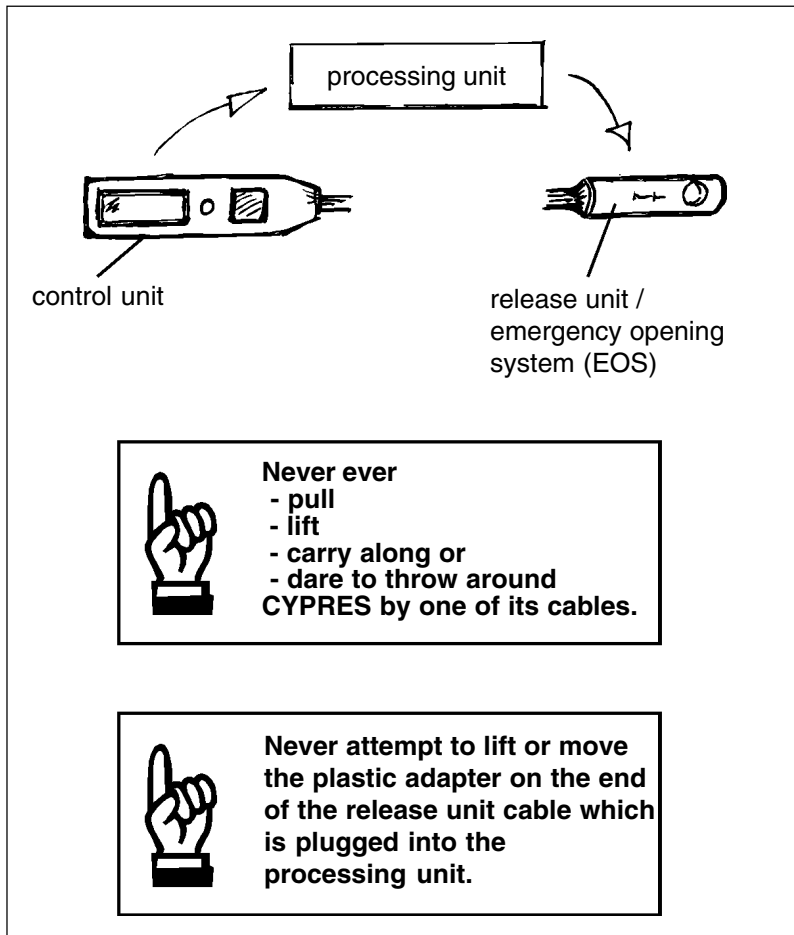

1.3 How CYPRES works

Every time CYPRES is switched on it will calibrate to ground elevation by measuring the air pressure several times in a short period of time and taking the average value as the value for ground level. This is happening during the integrated self-test. CYPRES doesn't stop here. While it is in use it will constantly check the air pressure on the ground and, if necessary, adjust to changing weather, e.g. air pressure. The very accurate calibration is basis for CYPRES to recognise exactly the activation altitude and activation of the release elements in case of exceeding activation speed.

The processing unit contains a factory-programmed microprocessor that is capable of real-time calculations of the jumper's altitude and rate of descent on the basis of barometric pressure.

By monitoring this data, certain criteria are generated from which conclusions are drawn. Should the conclusion be that the jumper is in a dangerous situation (i.e. still in freefall at a low altitude) the processing unit triggers the release unit to open the reserve container.

The release unit or Emergency Opening System (EOS) for the reserve container is completely independent of the rig's system, because it does not pull the ripcord pin out of the closing loop but actually cuts the loop inside the reserve container to release the pilot chute. This method is exclusive to CYPRES.

CYPRES' opening system has these advantages:

- The reserve container can be opened two different ways. One method is used by the jumper – pulling the reserve release handle; the other method is used by CYPRES when it cuts the closing loop.
- Mechanical components are reduced to a single movable bolt in the release unit. Processing and control functions are electronic-based.
- The opening system is situated inside the reserve container where it will not be exposed to external battering or other adverse influences.
- The system is unobtrusive and can be installed so that it is undetectable from the outside.

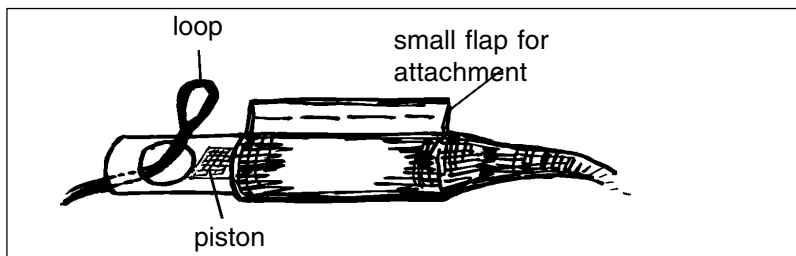

Schematic diagram of EOS function:

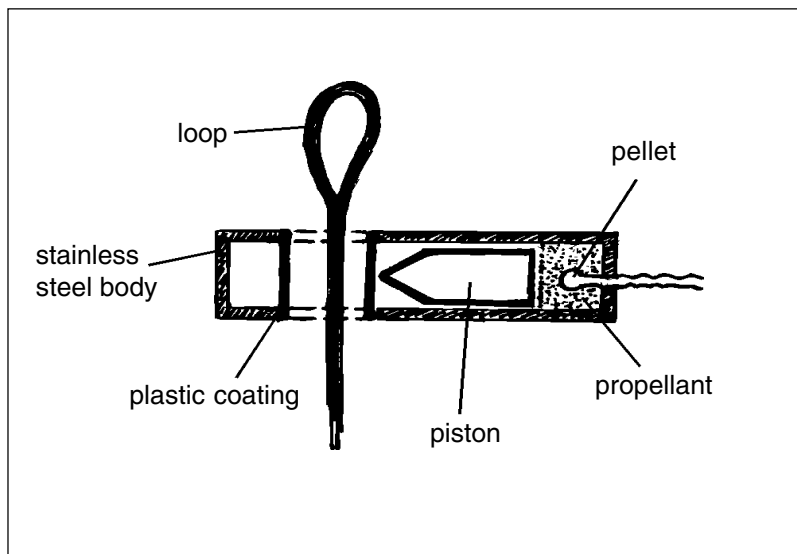

The distance which the piston moves in case of an activation is approx. 5 mm.

The cutter assembly (EOS) is completely self-contained. In the event of activation, there is nothing released. It was specially developed for CYPRES, and is classified as being non-hazardous.

1.4 Energy supply

CYPRES works with a battery that is calculated to last for approx. two years or approx. 500 jumps. The battery is a high-energy density type, with long life and low self-discharge. It consists of two round cells, and does not contain heavy metals. Each battery which has been installed in CYPRES has to be replaced after 2 years at the latest. In case that the rig or CYPRES will be out of use the battery should be removed and disposed of after 2 years to prevent possible damage. The battery can be replaced by the user, however, the procedure is tricky and demands considerable attention to detail. See pages 25-29 for full instructions.

The battery's current voltage is displayed during each activation cycle (see page 18). After the unit has been switched on, there is a self-test routine during which numbers beginning with 9999 count down rapidly toward 0. The countdown is interrupted for approx. three seconds at a value somewhere between 6900 and 5700. This interruption indicates battery charge. For example, suspension of the countdown at 6300 means that the actual battery voltage is approx. 6.3 volts.

When the self-test routine is repeated several times within a short interval, the displayed battery voltage will not be constant. This is normal and has nothing to do with the technical components of CYPRES but rather, properties of the battery. Typically, the voltage displayed during a second or third self-test cycle will be lower than the voltage displayed during initial activation. With further self-test cycles, voltage will rise again.

If the unit has not been used for a long time, the battery voltage shown on the display during the initial self-test can appear to be rather low. However, the voltage displayed does not indicate a discharged battery but it is merely due to certain properties of the battery.

The absence of an electric current over a prolonged period will result in the build-up of an internal protective layer which will minimize self-discharge.

This layer can be removed by simply switching the unit on and off a couple of times. You will then see that the battery voltage shown during self-test will rise again.

Battery failure or low battery voltage will be detected by CYPRES. At the end of the self-test cycle, CYPRES will stop with an error display of 8999 or 8998 and will not assume operating mode. This indicates that the energy supply of the battery is no longer within operational limits.

Replace the battery once the self test has stopped at 8998 or 8999 (voltage too low), after two years or after 500 jumps whichever comes first.

1.5 Operational safety

There are two important points to remember regarding the operational safety of CYPRES:

1. CYPRES self-tests automatically every time it is switched on. After every switching-on procedure, CYPRES executes a self-test routine during which all important internal functions are checked. **Usually, a positive outcome to this self-test should assure you of troublefree operation for up to 14 hours.**

When the display unit shows 0 , the self-test has been completed successfully. If the self-test has resulted in errors or discrepancies, CYPRES will not assume operating mode but will switch itself off while displaying an error code. This error code indicates why the activating process was abandoned (see page 24).

2. CYPRES has fail-safe error detection. Two processes are activated in CYPRES once the unit has been switched on: a primary working process and an independently operating controlling process that monitors the working process continuously. In case of errors while the working process is active, the back-up controlling process will switch the unit off.

Depending on the type and potential impact of the error, CYPRES can either be switched on again or it will stay in shut-down mode permanently. With certain error codes (see error code list on page 24), it is not possible for the user to reactivate the unit. In such cases, CYPRES must be sent back to the manufacturer for inspection and adjustment.

Remember: A positive outcome of the self-test should assure you a troublefree operation for up to 14 hours.

2. Product Overview

CYPRES is available in six models:

Expert CYPRES	for one-pin-container
Expert CYPRES	for two-pin-container
Student CYPRES	for one-pin-container
Student CYPRES	for two-pin-container
Tandem CYPRES	for one-pin-container
Tandem CYPRES	for two-pin-container

Meter/Feet version

Every CYPRES model is offered with an altitude calibration either in feet (30-foot steps) or in meters (10-meter steps). The different versions can only be distinguished from each other when the reference altitude is changed; otherwise, they are identical.

The "feet" version will display thirty (30) as a step difference, while the meter version will show a step interval of ten (10). See pages 21-22 for changes of reference altitude.

2.1 Expert CYPRES

The Expert CYPRES can be recognized by the red button on the control unit.

It activates the EOS when it detects a rate of descent higher than 78 mph (35 m/sec) at an altitude of apx 750 feet above ground level (AGL). In the event of a breakaway below this height CYPRES will operate down to apx 130 feet AGL. Below 130 feet AGL opening is no longer useful. For this reason, CYPRES ceases operation below apx 130 feet AGL.

2.2 Student CYPRES

The Student CYPRES can be recognized by the yellow button with the imprint "Student" on the control unit.

It will activate the EOS when the rate of descent exceeds 29mph (13m/sec). The activation altitude is split. In the case of rate of descent being equal to that of freefall the opening altitude is at approx. 750 feet, being the same as with Expert CYPRES. However, should the rate of descent be lower than that of freefall but still above the limit of 29mph (e.g. with partially opened canopy), then Student CYPRES activates the EOS when the altitude decreases below 1000 feet above ground level. The student will then have some more time to prepare for landing.



If a jump plane is descending without having dropped, switch the Student CYPRES off!



Unlike the Expert CYPRES models, we recommend that the Student CYPRES be switched off in the aircraft prior to descent if the jump is aborted and the student will land with the plane.



Be aware that it is possible to exceed a vertical speed of 29 mph under a fully inflated canopy!



2.3 Tandem CYPRES

The Tandem CYPRES can be recognized by the blue button with the imprint "Tandem" on the control unit.

It activates the EOS when it detects a rate of descent higher than 78mph (35m/sec) at an altitude of apx 1900 feet AGL.

3. Installation

CYPRES MUST ONLY BE INSTALLED BY A QUALIFIED RIGGER WHO HAS BEEN AUTHORIZED BY AIRTEC FOR SUCH INSTALLATION. IN RIGS WITH CYPRES SET-UP, CYPRES CAN BE MOUNTED BY ANY RIGGER OR RESERVE PACKER.

Definitions:

Installation: Doing a retrofit, sewing the pouch, cutter elastic(s), and cable housings into a container without CYPRES Set-up.

Mounting: Assembling the CYPRES into a container with an existing approved set-up.

CYPRES can be installed in rigs without adding to pack volume or changing their exterior profile. Both the processing unit and EOS are mounted inside the reserve container, while the control unit is placed either underneath the top flap next to the ripcord pin, or on the front of the harness to allow for easy access.

Because CYPRES is designed to fit within minimum volume requirements, thereby saving space wherever possible, its tolerance of abuse has been minimized in anticipation of careful handling by the user. For this reason, it is imperative to avoid twisting or pulling forces on the cable connections during installation or removal, as well as during normal usage.

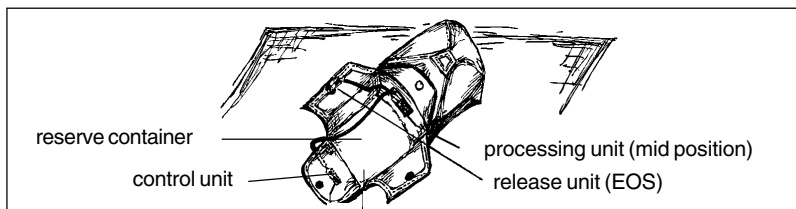

In the following sections (3.1, 3.2 and 3.3) you will find additional information regarding installation of the three components that make up CYPRES. However, CYPRES must be installed only by a qualified rigger who has been authorized by Airtec for such installation.

The "CYPRES Rigger's Guide for Installation" contains detailed instructions for the procedure, and the necessary tools are provided with a special rigger's kit.

It is of utmost importance for your safety that CYPRES be installed strictly according to the Rigger's Guide for Installation.

Should you obtain your CYPRES in a state readily installed, please make sure that you have a CYPRES reserve loop together with a disc and a CYPRES pull-up (two with two-pin CYPRES; plus 2 soft bodkins with two-pin Pop Tops) stored in the CYPRES pocket of your container.

Further, be sure that you get the following parts along with your CYPRES:

1 CYPRES reserve loop, 1 CYPRES pull-up (2 with 2-pins), 2 special packing bands (only with two-pin Pop Tops).

3.1 Processing unit

The processing unit must be positioned **centrally** on the partition wall separating the main and reserve containers, so that the reserve canopy material covers and surrounds the unit on all sides. This offers the best protection against temperature variations and impact damage.

For installation, the processing unit is placed into a specially bolstered and labeled nylon pocket which is supplied with every CYPRES.

Excess cable is stowed in the flat part of the pocket underneath the velcro-adjustable flap. If you have to stow both the thinner EOS cable and thicker cable to the control unit, be sure to place the thicker cable so that it lays on top of the thinner one. Cables should be placed in a circle in order to avoid twists. Always avoid pulling, bending, twisting, or kinking the cables.

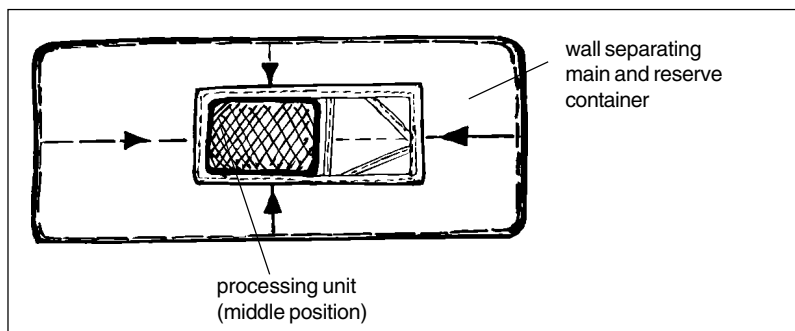

When placing the processing unit into its nylon pouch, make sure that the cables lie flat on the bottom.

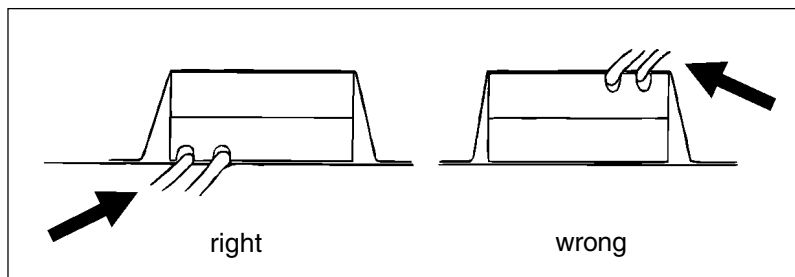

3.2 Release unit

Installation of the release unit (EOS) varies from system to system, depending on the design. Detailed information is contained in the "Rigger's Guide for Installation" and in individual equipment manufacturers instruction booklets.

To ensure correct operation of the release unit (EOS) the reserve closing loop(s) must be made of the correct diameter Polyamide material and the top except for 1/2" above the disc must also be silicone impregnated (but see page 39 for special instructions concerning single pin pop-top containers). The silicone reduces wear and tear and increases flexibility of the loop. Furthermore, the force needed to pull the reserve ripcord pin is reduced.

Loops supplied by Airtec are pre-treated on the first 2".

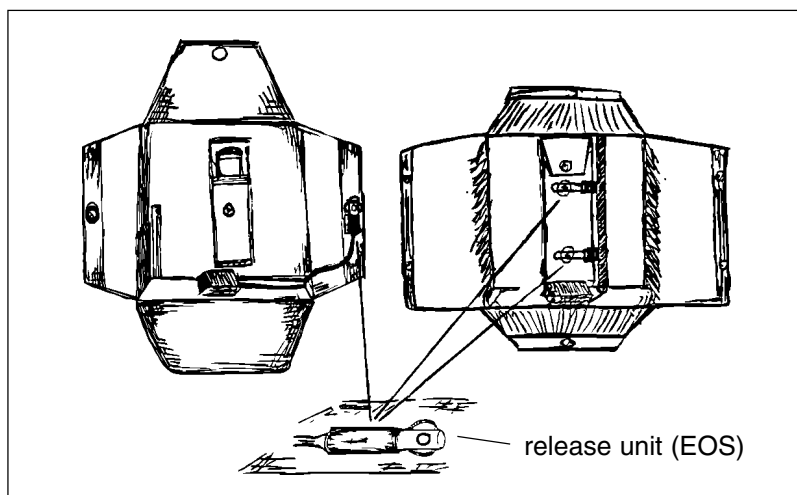

The release elements have to be mounted like described in the CYPRES Rigger's Guide for Installation.

NOTE: WHEN CYPRES IS INSTALLED ONLY USE RESERVE CLOSING LOOPS SUPPLIED BY AIRTEC.

3.3 Control unit

The control unit

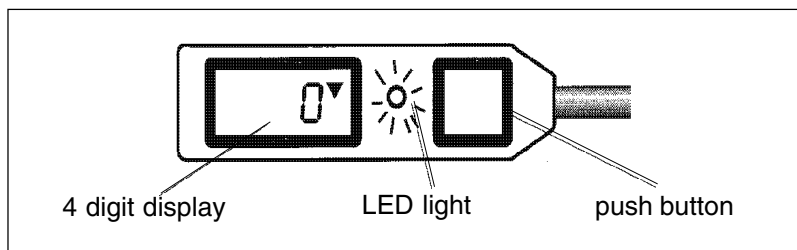

is placed underneath the top flap next to the ripcord pin.

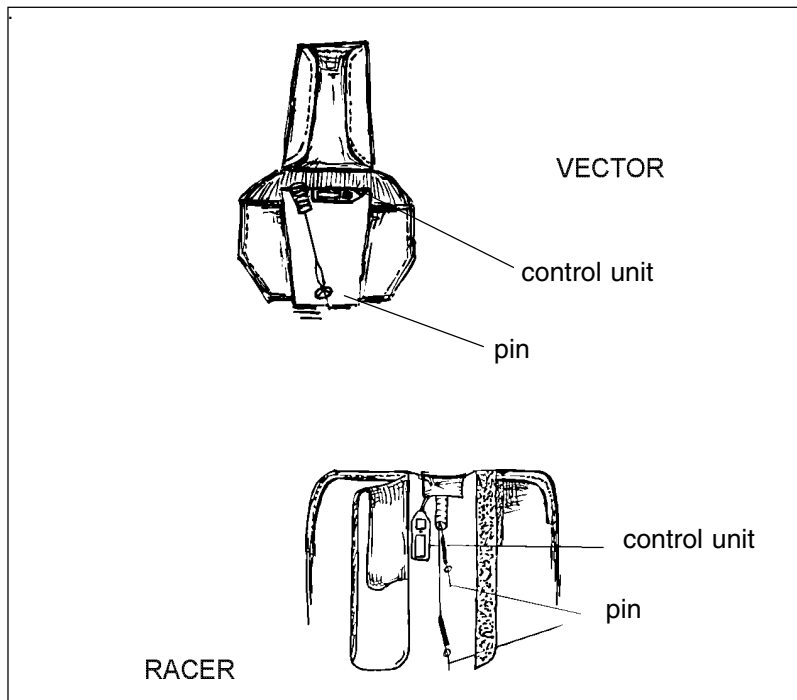

The control unit should be attached using the four small nylon ties built into its bottom surface. These ties can be pulled through nylon layers with a needle and then secured with appropriate knots.

This method of attachment places the knots out of sight and is therefore visually pleasing.

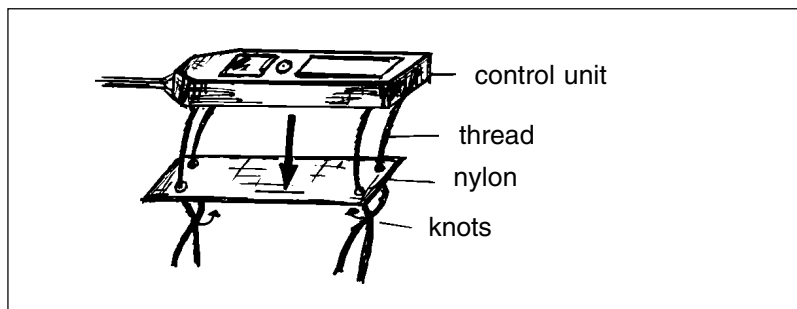

Alternatively the transparent pouch (supplied with the installation kit) can be hand sewn or machine stitched under the reserve top flap. The control unit is then pushed into the pouch and not sewn directly to the rig.

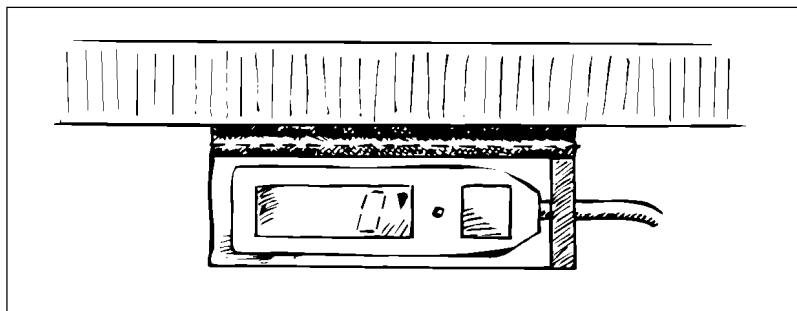

When inserting your hand-deploy in a pilot chute pouch on the bottom of the container do not turn the rig upside down. This can damage the control unit cable if the control unit is located in the collar area of the rig.

An alternative method for mounting the control unit is to use the velcro strip supplied with the unit.* Both velcro components have an adhesive coating.

For added security we recommend that the pile portion of the velcro (velcro 2) is secured to the rig by sewing or tacking in addition to the adhesive. The use of velcro raises the control unit by four (4) millimeters.

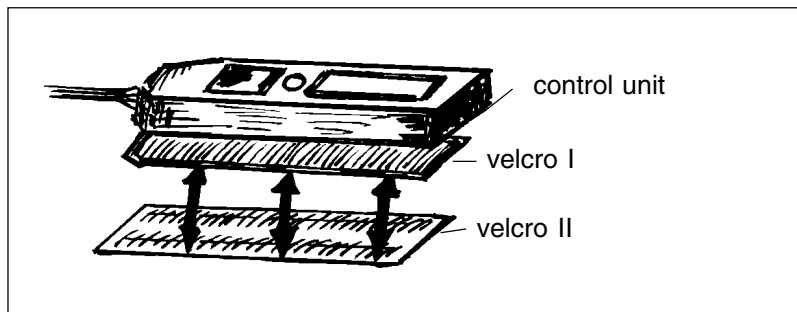

Once the control unit has been mounted, make sure that it cannot interfere with the reserve container opening, the ripcord, the pin(s).

Inside the reserve container, the nylon pockets supplied with CYPRES must be used to install both processing and release units. The nylon cable housing should be used to encase all cable. You will find these installation components in one of the plastic bags.

NOTE: CYPRES MUST ONLY BE INSTALLED BY A QUALIFIED RIGGER WHO HAS BEEN AUTHORIZED BY AIRTEC FOR SUCH INSTALLATION.

*since 1.1.98 only supplied on request

4. How to Operate CYPRES

4.1 Handling the control unit

The pushbutton on the control unit should be pressed with the fingertip alone; please do not use a fingernail. Use a short pushing action in the middle of the button (like a click).

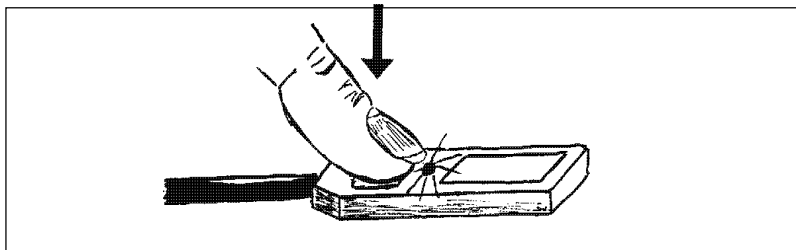

You should familiarize yourself with switching CYPRES on and off and changing reference altitudes (pages 17, 18, 20 and 21) prior to installing and using it.

The pushbutton is the only means the user has for controlling CYPRES functions. Through it, the following four actions are initiated:

- switching on
- switching off
- increasing reference altitude
- decreasing reference altitude

The following pages provide thorough descriptions of these four procedures.

4.2 Switching CYPRES on

CYPRES is switched on by pressing the pushbutton four times with short dry clicks. You initiate the switching-on cycle by clicking the button once. After approx. one second, the red LED-light will glow. You must acknowledge the red light immediately by clicking the button again. This sequence — a click following appearance of the red light — will be repeated two more times. After a total of four clicks, CYPRES goes into operating mode.

If you do not act promptly after seeing the LED-light, or if you push the button too soon, CYPRES will ignore the switch-on attempt. Simply try again — it's easy once you've done it.

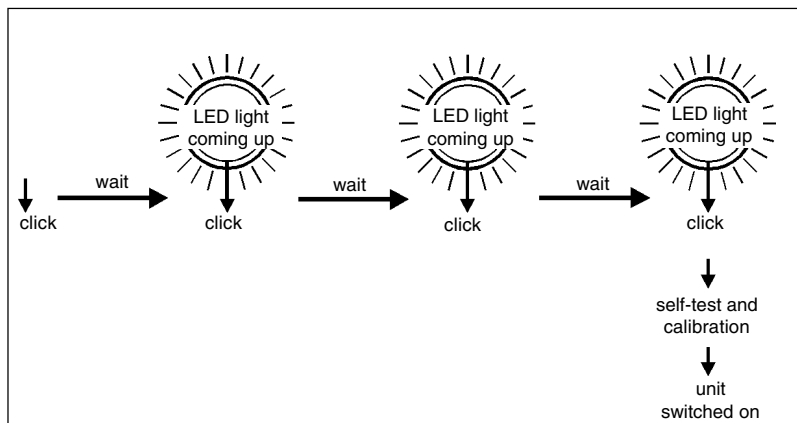

This four-click initiation cycle has been designed to avoid accidental activation.

Once the switching on procedure is finished, the unit will run through its self-test. Initially the display will show the number 9999, and then a rapid countdown ending in 0. The countdown will take 29 seconds, and will be interrupted three times.

There will be a three-second pause between the numbers 6900 and 5700. The number displayed at this pause will indicate the actual battery voltage (e.g. 6300 means 6.3 volts). The second and third pause will last approx. one second each, and will occur at 5000 and 100. These pauses are for technical reasons only and have no meaning to the user.

During its self-test, CYPRES will measure the air pressure several times. Should the unit detect large differences between pressure values, it will conclude that there is a problem and will not proceed to operating mode. In such a case, it will abort its self-test and display the number 100.

Any functional defect will also cause CYPRES to abort the self-test and display a number for approx. two seconds before switching itself off. This number is an error code. Error code numbers are listed on page 24 along with their respective causes.

After the self-test has been completed or after you've switched off the unit, CYPRES will ignore further inputs for one second.

Once activated, CYPRES will remain in operating mode for 14 hours, after which it will switch itself off. Of course the unit can be switched off manually at any time.

The manual switch-off sequence is the same as the switch-on procedure. Again, this routine is designed to avoid accidental deactivation.

4.3 When to switch on or re-set

CYPRES measures and locks in the altitude at the site where it is activated. As a rule, CYPRES should be switched on close to the take-off site on the ground. Just prior to donning your rig is an ideal time. It should never be switched on inside the aircraft, helicopter, balloon, etc.

To re-set CYPRES, switch off and then on again. The unit will then re-calibrate itself.

When the airfield and dropzone are in the same location and all jumping activity is restricted to that place, an initial activation on the dropzone will suffice for a number of jumps, provided they all take place within 14 hours. Should any of the following situations occur however, CYPRES must be re-set before the next jump:

- The dropzone is missed and the landing takes place in an area with an elevation greater than 30 feet (10 m) above or below the dropzone level. Or, on the return journey to the dropzone the ground elevation changes similarly.
- The unit is taken away from the airfield/dropzone by vehicle or on foot and later brought back again.
- If the total flying time for a single jump lift exceeds one and a half hours CYPRES will function normally but must be re-set after landing.

When the airfield and dropzone are in different locations, CYPRES must be switched on at the departure airfield. On return to the airfield from the dropzone it must be re-set before jumping again.

When the airfield and dropzone are in different locations and at different elevations, CYPRES must be switched on at the departure airfield and adjusted to the elevation of the dropzone (see pages 21 and 22 for full instructions). This is extremely important when making demonstration/display jumps. On return to the airfield from the dropzone it must be re-set before jumping again.

General recommendation: If in doubt, re-set CYPRES. The battery life is designed to cope with this and will not be adversely affected.

4.4 Changing altitude reference

You have to change the reference altitude whenever the airfield and the dropzone where you intend to land are at different elevations. CYPRES allows for adjustments of up to plus/minus 1500 feet, or plus/minus 500 meters if you have a meter version.

In order to make the adjustment, simply leave your finger pressed firmly on the button when you press it for the fourth time. CYPRES will continue with its self-test, and once it has finished, it will display altitude differences in steps of 30 feet (or 10 meters). For example, CYPRES will display the number "30" ("10") on the display next to an arrow pointing upward. (30 or 10▲ ▲)

In this way, CYPRES is asking if the intended landing spot will be at a place 30 feet (10 meters) above airfield elevation. The figure "30" ("10") will remain on the display but the arrow will switch direction, now pointing downward (30 or 10 ▼). At this point, CYPRES is asking whether the landing site will be 30 feet (10 meters) below airfield elevation. (Be sure to use above-ground-level altitude; never above-sea-level references.)

Following this, "60" ("20") will display next to an arrow pointing upward. CYPRES now is asking whether you intend to land 60 feet (20 meters) above airfield level. Once again the arrow will change, pointing downward. CYPRES asks: "Landing 60 feet (20 meters) lower?"

This back-and-forth routine between up and down, in increments of 30 feet (10 meters), continues up to an altitude difference of 1500 feet (500 meters). The pushbutton must remain pressed until the desired altitude comes up on the display. When you see the appropriate altitude, release the pushbutton.

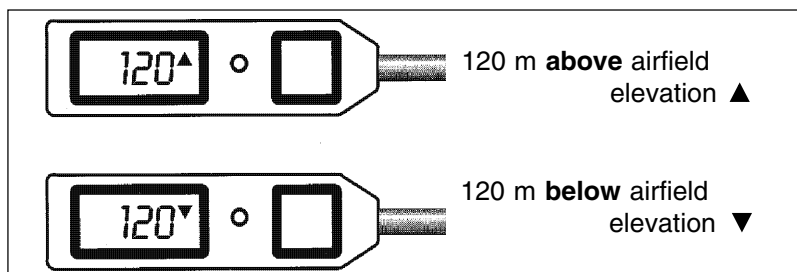

The altitude difference you select will remain indicated on the display, and CYPRES will adjust automatically for these changes during the next jump.

When making altitude adjustments, make sure that the pushbutton remains depressed from the end of the start-up sequence (the fourth click) until the moment the altitude difference you desire shows on the display.

Even the shortest release of the pushbutton during the self-test cycle causes an interruption in the process, and CYPRES will ignore further attempts to change altitude reference. In such cases the unit will run through its self-test and end with 0 on the display, ready for operation (without altitude difference adjustment). Simply repeat the procedure as necessary.

Each attempted but unsuccessful input of altitude changes will be ignored by CYPRES. If you want to make changes, you have to start your input all over again.

Once you have made an altitude change, it will be displayed until the jump has been made, or until CYPRES switches itself off or is switched off by you.

On landing, CYPRES will accept the new ground level as its actual "Ground Zero" reference, when the preset altitude has been hit precisely. This action can be observed by noticing that immediately after the landing (within a maximum of 30 seconds), the preset and displayed altitude difference is automatically replaced by zero.

It would be possible to take off from this elevation and land there again under canopy without doing any further altitude adjustment. But, if you take off at this elevation and jump into a dropzone with different elevation you have to do another altitude adjustment.

If the preset altitude does not equal the actual altitude on landing (e.g., because the exact difference was not known and was estimated) the unit will not change to zero display right away. In such a case, CYPRES must be recalibrated to the correct Ground Zero by switching it off and on again prior to the next jump. Do this on the airfield where the aircraft will take off.

Important: It is necessary to do an altitude adjustment before **every** individual jump, whenever the airfield and the dropzone where you intend to land are at different elevations.

4.5 CYPRES and water jumps

When you intend to perform a water jump, you must remove CYPRES prior to the jump. Do not reinstall it until the rig has been dried out completely, because CYPRES is NOT moisture-proof.

If you have made a jump into freshwater with CYPRES installed, and there has been only a short contact with the water, there may be no harm caused to the unit. This can be checked by an immediate inspection of the installation pocket or the outside of the processing unit to make sure they are not wet.

However, should you detect humidity in the installation pocket or on the outside of the processing unit, we recommend that you send CYPRES back to us with a short description of what happened. We will inspect it to ensure its continued safe operation. Due to the fact that saltwater is an aggressive fluid we recommend to avoid any contact of saltwater and CYPRES.

5. Errors Display

If the unit once failed the self-test due to low battery voltage (error code 8999 or 8998), it is absolutely necessary to change the battery. Because of special characteristics of the battery, it is possible, that a second try to switch the unit on will be successful. In this case it is not guaranteed, that the CYPRES will work correctly.

In the event of an error inside the unit the countdown will stop before reaching „0▼“ and CYPRES will automatically switch itself off after approx. 2 seconds. The height at which countdown stops indicates the reason for error as shown in the table below:

8999	Battery voltage is too low.
8998	The most probable cause will be a discharged battery.
Whatever happens, please replace the battery with a new one.	
8997	The cable of a release unit or both release units have an electrical connection error. The reason could be a broken wire.
100 oder 4000	Excessive variations in ambient air pressure have been measured during the self-test period. The unit is unable to obtain consistent values for the ambient air pressure at ground level. Possible reasons could be that an attempt to switch CYPRES on has been made in a car driving uphill or downhill, in an elevator, or in a flying aircraft.
9999 9998 9997 9996 5000 8995 8994 8993 8992 8990	Should one of these numbers be displayed for approx. two seconds, after which the unit switches itself off, you should try again to activate the unit and repeat the attempt after a short delay six more times. If this still results in an error display, please send the unit back to the manufacturer.

If any of these numbers are displayed during normal operation after a successful self-test they do not indicate an error and can be ignored.

In this situation, after successful self-test, these different number displays have no influence on the unit's ability to function correctly. Should you wish however to return the display to 0 again, switch the unit off and on again on the ground.

6. Maintenance

6.1 Removal of the unit

Once CYPRES has been installed, it can be removed from the rig without requiring the services of a rigger. This will take approx. three minutes once the reserve container has been opened. Reinstallation will require a similar time, not including the pack job.

For either removal or reinstallation, both the reserve and the main containers must be empty. It is necessary to work very carefully, making sure that the unit's cables are never twisted or bent.

Also, to avoid unnecessary stress on the nylon housings, we recommend that you never remove or reinstall the unit without good reason.

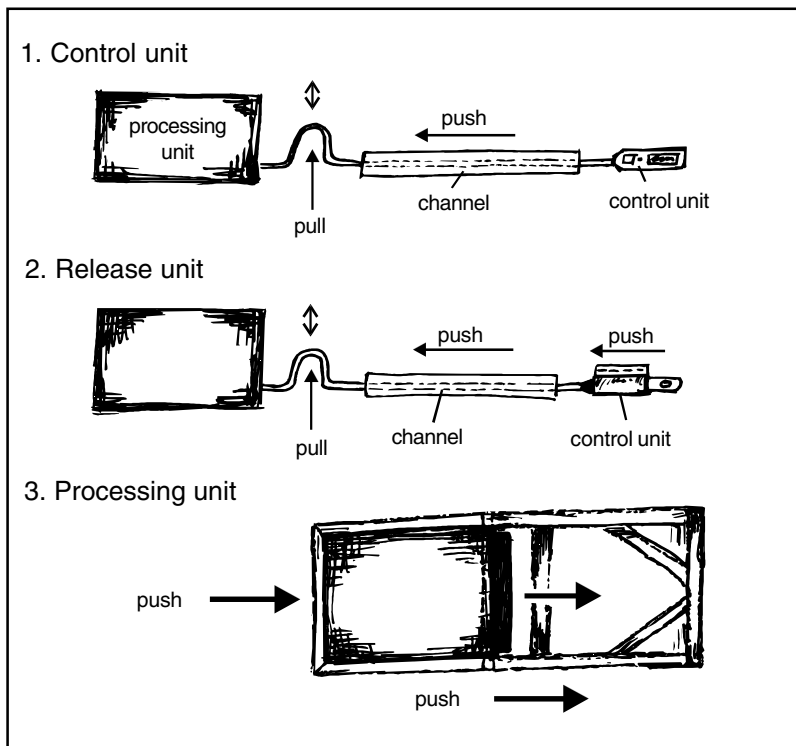

6.2 Replacing battery

For information when to replace the battery, refer to page 7.

Note that you yourself or your rigger can change the battery, the CYPRES unit **does not** have to be sent to Airtec or SSK.

Although you may assume that CYPRES' battery is similar to other batteries you may see for sale (same voltage, same size), **you must not use them**. They are stick-type batteries; batteries of coiled type must be used in CYPRES instead. Stick-type batteries have a lower energy density, different temperature ranges, discharging characteristics, etc.

CYPRES has been designed to be small so it takes up as little space as possible in your reserve container. Consequently, its wiring attachments and closure elements are small and delicate. That is why replacing its battery requires a gentle hand, a calm mind, a bit of skill, and some time. It is not a procedure to be rushed through.

! Do not open the battery compartment without having a good reason !

Battery replacement starts with removal of the battery compartment cover. This is accomplished by loosening the two slotted screws embedded in recesses on top of the unit. Use the screwdriver supplied with CYPRES.

Each screw will be loosened with approx. four anticlockwise turns. After this, the cover can be removed by lifting it straight upward. Both screws remain in their guide holes in the cover plate.

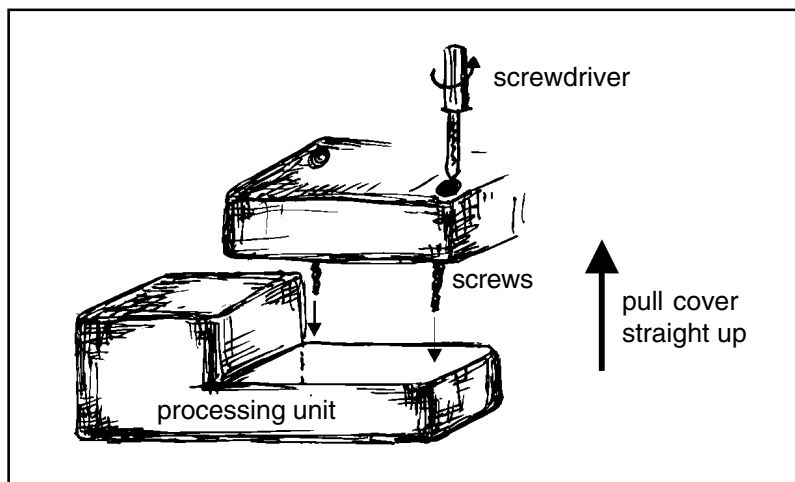

Grasp both battery cells gently between thumb and index finger, and lift them cautiously straight up approx. one centimeter, until their lowest point is at level with the edge of the opened battery compartment.

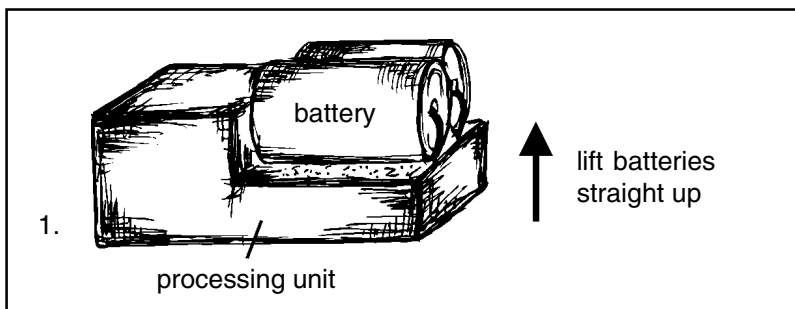

Then, tilt the battery carefully as shown, and place them outside of the container, upside down.

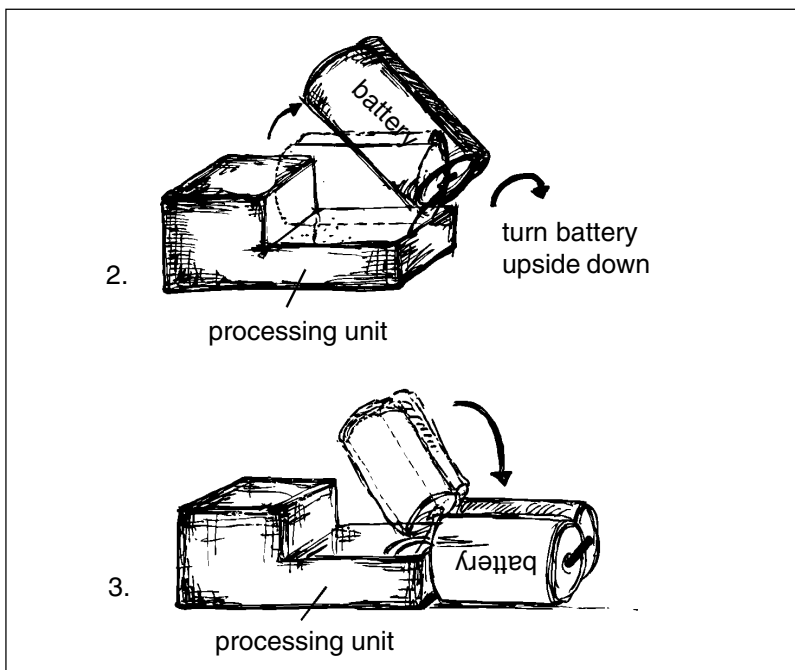

Disconnect the blue battery plug, which has now become visible, by holding its blue plastic cover at its exposed end and pulling it out of its casing. You must NOT use the battery cable coming out of the housing to pull out the plug, because this might destroy the contact inside the processing unit.

Keep track of battery currency by recording the date each time you change the battery on the time chart located on the bottom of the container. Additionally record the date on the sticker which comes with the battery-set. Put the sticker on the outside of the processing unit. This sticker provides the possibility of checking the age of the battery each repack.

To insert the new battery correctly, first place them in front of the opened battery compartment. Make sure that the two poles to which the battery cables have been soldered are facing the container and that both cables are pointing upward.

Place the plug connecting both battery cables on the bottom of the container, and then push it gently over both plug contacts. Make sure that the two small lugs extruding from the plug's front end point upward (they must be visible.)

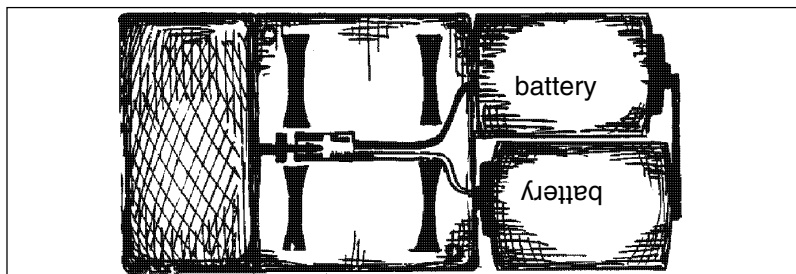

Then, position both battery cells between your thumb and index finger on their right and left sides, and turn them upside down toward the unit's closed casing until they are in a position exactly overhead the opened battery compartment. From this horizontal position, they can now be lowered straight into the battery container.

To avoid damaging battery contacts, make sure that you do not pull on the battery cables at any time.

Very important:

The battery cables must lay **between** both moulded battery brackets in the battery compartment to avoid them being squeezed between brackets and battery.

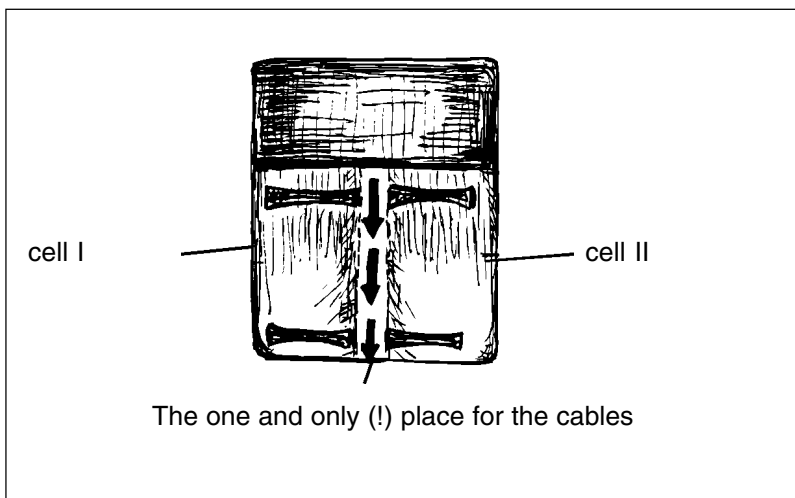

Finally, replace the top of the compartment in its original position, so that the two screws protruding downward fit securely into their holes in the bottom of the compartment, without forcing. Tighten both screws with approx. four cautious clockwise turns, once their threads have been engaged.

It is important that the threads of the screws do not damage the batteries. Make sure that you just push the screws past the batteries down into their holes, do not turn them when advancing. Once both screws are down, tighten them with approximately four cautious clockwise turns once their threads have been engaged.

The battery contains an internal unrepairable fuse. This fuse is very sensitive and will react immediately to any contact between two battery poles, however briefly it may last. A breakdown means that the battery has been rendered unusable. Therefore, please use caution in handling CYPRES' batteries.

Once battery replacement has been completed, the unit's operational status should be tested by performing one switch-on and switch-off procedure.

6.3 Changing the release unit

A release unit which has fired can be changed in general by any rigger or packer. This is possible, when the CYPRES is provided with the field replaceable cutter. It can be recognised by the plug on the release element cable. A CYPRES with an "old" cutter must be returned to our Service-Center in the US hosted by SSK Industries, Inc. or your local CYPRES dealer.

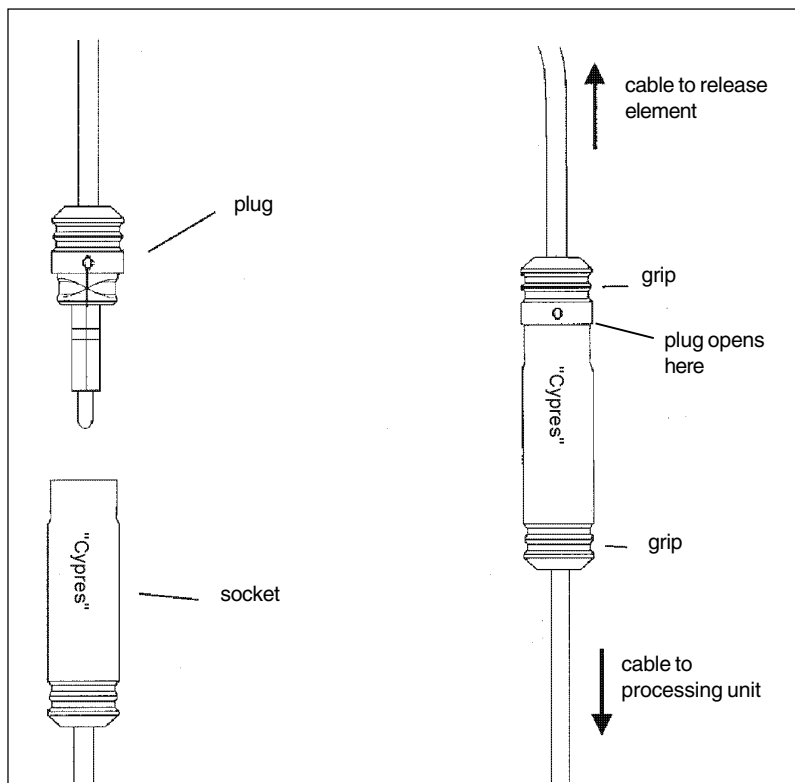

Disconnecting the plug connection:

Hold plug and socket by their grips and pull them apart using a smooth **STRAIGHT** motion. Do not twist them!

Connecting the plug connection:

Hold plug and socket by their grips and connect them by pushing together with a smooth **STRAIGHT** motion until you feel a slight click.

6.4 Technical service

4 years and 8 years after date of manufacturing, CYPRES must receive the manufacturers check-up and technical evaluation. Its function technically and under all temperature conditions will be tested with the same methods used during the manufacturing process — methods for checking and measuring all aspects of the unit's accuracy in order to ensure it will function properly, even in extreme conditions.

Please keep the container in which CYPRES was shipped to you and use it to ship the unit for technical evaluation to your local CYPRES dealer. When preparing CYPRES for mailing, please stow the cables in a clockwise direction around the processing unit. Make sure the cables are not twisted at their exit points.

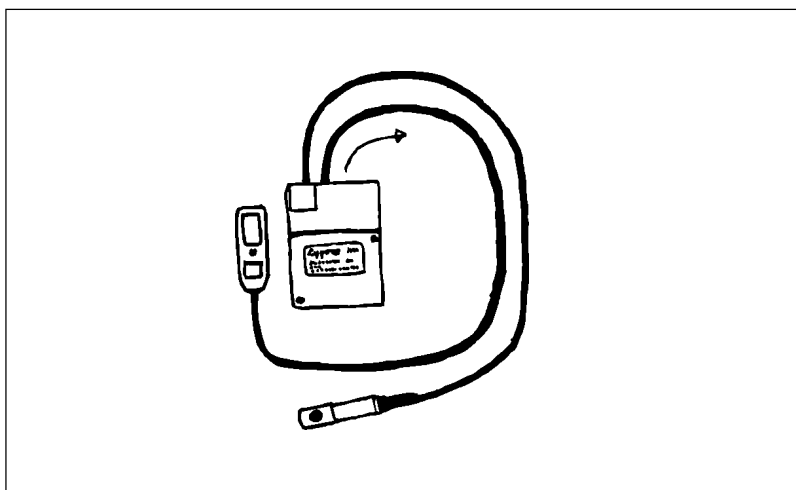

The CYPRES Service Center for the USA, Canada and South America and other Western Hemisphere Countries is:

SSK Industries, INC., 1008 Monroe Road, Lebanon OH 45036, USA,
Tel: ++1 513 934 3201, Fax: ++1 513 934 3208 email: info@cypres-usa.com

For all other countries, please send your CYPRES to your local CYPRES dealer. If you don't know who that is please contact Airtec.

7. Important Notes

7.1 Important notes for jump pilots

- A Student or Expert CYPRES will not work if the aircraft is exited before it reaches 1500 feet (450m) above the height at which the jumper intends to land. In case of a Tandem CYPRES 3000 feet (900m) has to be reached. Once the aircraft has climbed through that altitude and CYPRES has become fully operational it will work for any exit height.
- An aircraft must never descend to altitudes below the elevation of the airfield of departure.
- If CYPRES has been adjusted to an altitude above airfield level and the aircraft has climbed above the elevation of the intended dropzone, it must not descend below that altitude again.
- If CYPRES has been adjusted to a drop zone altitude below airfield level, the aircraft must not descend below an altitude corresponding to the elevation of the intended drop zone.

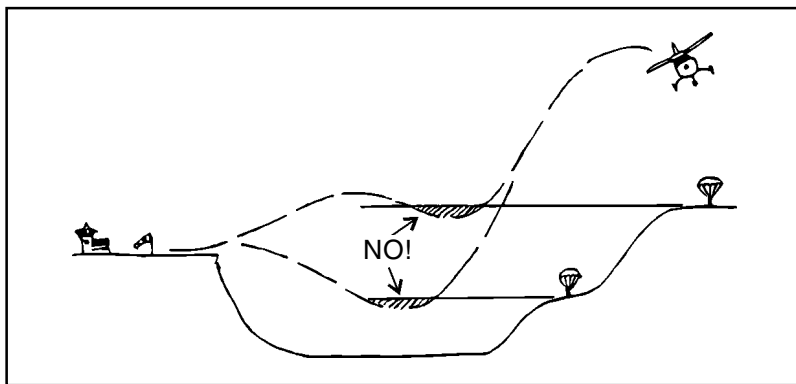

- When using a pressurized aircraft, make sure that the cabin remains open when the turbines are started up. Leave a window, a door, or the ramp open a bit until after lift-off. This will ensure that cabin pressure cannot build up above the air pressure on the ground.

It is the skydiver's responsibility to make sure that jump pilots are informed of circumstances that will interfere with CYPRES' proper functioning. Should a jump pilot be unable to comply with these requirements, or should you discover after a jump that the requirements have not been met, you should switch CYPRES off and on again prior to the next jump.

7.2 Important notes for users

- CYPRES must not be used for parasending or paragliding/sailing.
- CYPRES cannot be used for base jumps (jumps from fixed objects), and must be switched off prior to making a base jump with the rig on which it is installed.
- A Student or Expert CYPRES will not work if the aircraft is exited before it reaches 1500 feet (450m) above the height at which the jumper intends to land. In case of a Tandem CYPRES 3000 feet (900m) have to be reached. Once the aircraft has climbed through that altitude and CYPRES has become fully operational it will work for any exit height.
- Replace the battery once the self-test has stopped at 8998 (voltage too low), after two years or after 500 jumps, whichever comes first.
- CYPRES is shielded against radio-transmitter signals. The electromagnetic shielding has been developed with tremendous input of our effort and has been investigated thoroughly. Airtec managed to give CYPRES an extraordinary shielding, but it is impossible to have a 100% protection. We still recommend to avoid strong radio-transmitters.
- A release unit that has activated builds up a high internal pressure and will remain pressurized. Never attempt to open it by force. It can, however, be stored safely for an indefinite period of time, provided that it has not been damaged.
- A good reserve pilot chute is an important safety factor. On systems with an internally-mounted pilot chute, we recommend that owners equip their rigs with one that has been Airtec tested and subsequently qualified by Airtec and the rig manufacturer. Typically the rig manufacturer delivers these pilot chutes with the rig. If there is any doubt, please contact Airtec.

8. Repacking of Reserves



Generous treatment of CYPRES loops with silicone is improving the reserve container opening considerably.



General information:

At every repack the loops must be checked carefully and be replaced if necessary.

Grommets

Grommets with rough edges ultimately will destroy any loop. Replace damaged grommets immediately.

Reserve loops

The reserve loop must be placed under a tension factor of at least 5 kg once the reserve has been packed. The loop material has a maximum extensibility of 7.5 percent. Maximum extensibility is the length to which the material can be stretched before it will break.

By contrast, the maximum extensibility of Kevlar material, which is considered to be quite rigid, is 5.2 percent.

We recommend that you pull on the loop twice, as firmly as possible, prior to installation. The elongation of the loop after installation should not exceed 3 millimeters in the case of a one-pin container, and 6.5 millimeters in the case of a two-pin container.

The loop material has a diameter of approx. 1.6 millimeters and a tensile strength of approx. 180 kp. The threaded area (where the loop is pulled through itself) has a higher tensile strength.

Because both the loop and the pull-up material consist of polyethylene, all actions which might build up excessive heat by friction should be avoided. Otherwise, the material will lose some tensile strength at temperatures above 100 degrees Centigrade (C°), and might even melt in extreme cases. Such stress can be put on the loop when the pull-up is passed through the loop or pulled out after packing is completed.

**! Therefore, be sure to extract the pull-up only from below the ripcord pins !
and only very slowly.**

The looped end of the CYPRES loop should be impregnated with silicone except for 1/2" next to the disc. Ready-made loops provided by Airtec have already been treated with silicone the first 2". **Running loops should be impregnated completely.**

In addition, we suggest that you prepare one further reserve loop of the appropriate length when installing CYPRES, and leave it together with the disc and a CYPRES pull-up (2 with a two-pin CYPRES and two softbodkins with two-pin Pop Tops) in the nylon pocket along with the stowed cable. This will provide you with a new loop and pull-up whenever you need one.

Plan to have sufficient loops for scheduled reserve repacks. Then the loop(s) in the spare pocket will always be available in the event of a real reserve deployment and repack.

Replace the spare loop(s) as soon as possible.

Stowing the canopy:

When stowing the reserve canopy into the freebag, be sure to take into account that:

1. The processing unit is located in the middle of the wall between reserve and main compartments of the container.
2. On one-pin containers in which the release unit has been placed above the pilot chute, there will be extra thickness (8.4mm) caused by the release unit's placement on top of the pilot chute.

Try to pack the reserve so that CYPRES' visibility is minimized.

8.1 Packing of one-pin reserve containers

When packing a one-pin reserve container in which CYPRES has been installed, be sure to note these important points:

- Use only original silicone impregnated CYPRES loops and original CYPRES discs (delivered with the unit.). The loops provided by Airtec are impregnated on the first 2". The use of thicker loops could prevent proper functioning of the system.
- Use only the original CYPRES pull-ups (delivered with the unit.)

Apart from these instructions, follow all other regular packing procedures described by your system manufacturer.

In order to avoid wear between loop, bottom disc, and knot where the loop attaches to one-pin containers, we have developed a new technique for affixing the loop. This technique utilizes a metal disc with three holes together with a special knotting technique.

Installation using this technique will not take significantly longer than the procedure previously used, with the added advantage that the entire loop system will have a higher tensile strength.

Every CYPRES intended for installation on one-pin containers is shipped with two of these special discs and three prepared loops. Follow these instructions for attaching the loops to the discs:

- a) pass the loop cord through the central hole and mark the desired length with a pen
- b) route the cord back through one of the outside holes
- c) and upwards again through the third hole
- d) hold the disc between the index and the second finger and trap the spare cord with the thumb. Pass a pen through the loop and sharply pull the whole loop cord twice to prestretch the material. Re-align the pen mark with the disc and knot the cord as shown in sketch e
- e) make one further knot as shown in sketch f to prevent slippage
- f) the looped end of the CYPRES loop should be impregnated with silicone except for 1/2" next to the disc.

! Caution: Don't use other knots than suggested !

Sketch of loop attachment:

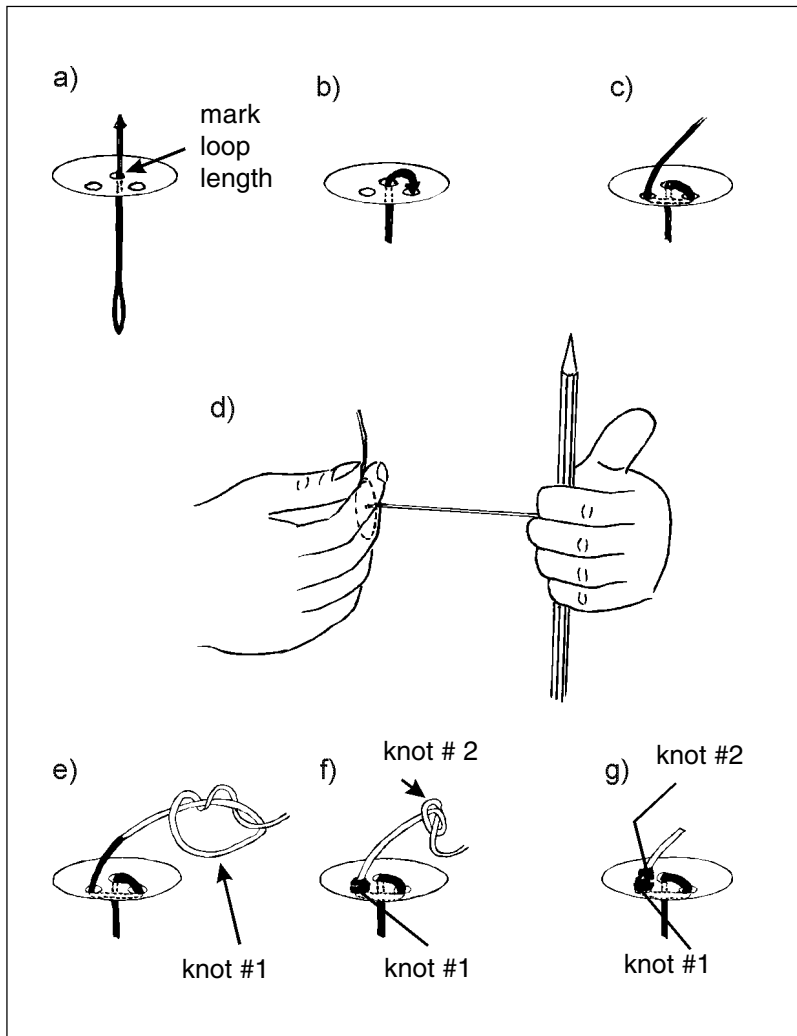

8.2 Packing of two-pin reserve containers

These points apply when packing a two-pin container in which CYPRES has been installed:

- Use only original silicone impregnated CYPRES loops (delivered with the unit). The use of thicker loops could prevent proper functioning of the system.
- Impregnate Running loops completely with silicone. If two one-pin loops are used the looped ends of the CYPRES loops should be impregnated with silicone except for 1/2" next to the disc.
- Make sure that the loop can run freely through the double bottom of the container.
- If the release unit is not mounted on the bottom of the container, lengthen the loop approx. two centimeters (2cm) to allow for the added thickness.
- Use only the original CYPRES pull-ups (delivered with the unit.)

Except for these instructions, follow all other regular packing procedures described by your system manufacturer.

8.3 Packing of one-pin Pop Top reserve containers

When packing a one-pin Pop Top System,

- Use only original CYPRES loops and CYPRES discs (delivered with the unit.) If the loop needs to be replaced, use an identically-made loop of original CYPRES loop material.
- For one pin Pop Top systems Airtec recommend that the closing loop is not silicone impregnated. If your CYPRES is for this type of rig please ask the authorized rigger doing the installation to fit a non-impregnated loop.

Except for these instructions, follow all other regular packing procedures described by your system manufacturer.

8.4 Packing of two-pin Pop Top reserve containers

When packing a two-pin Pop Top System

- Make sure that a Running loop has been installed.
- Use only original CYPRES loops (delivered with the unit).
- Impregnate the Running loop completely with silicone.

The Running loop

The Running loop has the characteristic that even when you pull only one of the two pins, the pilotchute will launch. The free end of the running loop slips through the channel in the pilotchute. The loop is NOT fixed on the pilotchute top. It runs in the running loop channel, which is provided with every 2-pin CYPRES installation set.

The running loop is easy to change (Just pull a new one through).

A 16cm (ca.6,3in.) running loop housing is supplied with every 2-pin CYPRES. Should you require a housing of different length please contact Airtec for immediate delivery.

When making your own housings ensure that the ends are not cut with a hot knife. This leaves a sharp edge and can damage the running loop. The ends should be folded back and sewn in place in exactly the same way as on those supplied by Airtec. Handstitch the running loop housing to the top disc of the pilot chute with strong wax thread. Cross-stitch all four corners.

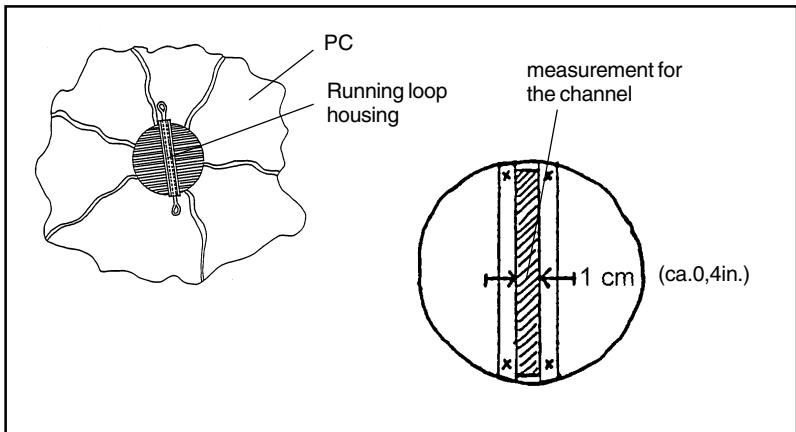

Loop installation in two-pin containers

CYPRES loops should not be shorter as those normally used on any particular harness container system (rig).

- a) Assess the loop length required and adjust the loops accordingly.
- b) Then, stretch the loop by pulling tight on both ends at least twice. The pulling force is what matters, not the duration of the pull. A short but decisive pull will do.
- c) Adjust the loop by gently pulling the finger trapping until it is 1 cm shorter than its desired length. Cut the protruding surplus ends with a scalpel or razor blade to a length of approximately 3mm (ca. 0,12in.). Then slowly pull the finger trapping until the surplus 3mm (ca. 0,12in.) of material disappear inside the loop. The central 6cm (ca. 2,4in.) of the loop should be sewn with nylon type E thread or similar material, by hand or machine. Both ends of the stitching should be locked. 2-pin loops provided by Airtec are not treated with silicone, please impregnate the complete running loop with silicone. When making up your own loops, use only Airtec polyamide material. Make exact copies of original loops and do not forget to treat the complete running loop with silicone.
- d) Finally, stretch the loop twice more.

This should result in a smooth, protrusion free loop of the required length.

Once the required loop length has been established it should be annotated on the reserve packing card for future reference. The silicone gel supplied by Airtec is ph neutral and does not affect Parapack, Cordura or Canopy material.

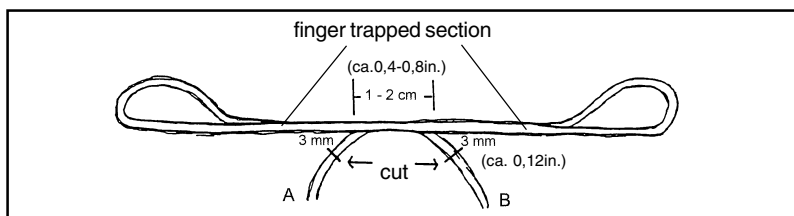

Important: The loose ends A and B should overlap in the centre of the made up loop by 1 to 2cm (ca.0,4-0,8in.).

The running loop, ready to install after sewing and siliconing :

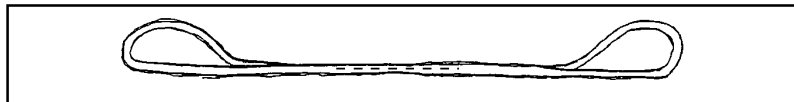

Packing

There is a simple technique using two special lines made of CYPRES loop material (soft bodkins) together with the CYPRES pull-ups. These lines and pull-ups will be shipped with every CYPRES ordered for a two-pin system. The packing procedure is described on the next pages.

Schematic drawing of a two-pin Pop Top reserve system with CYPRES:

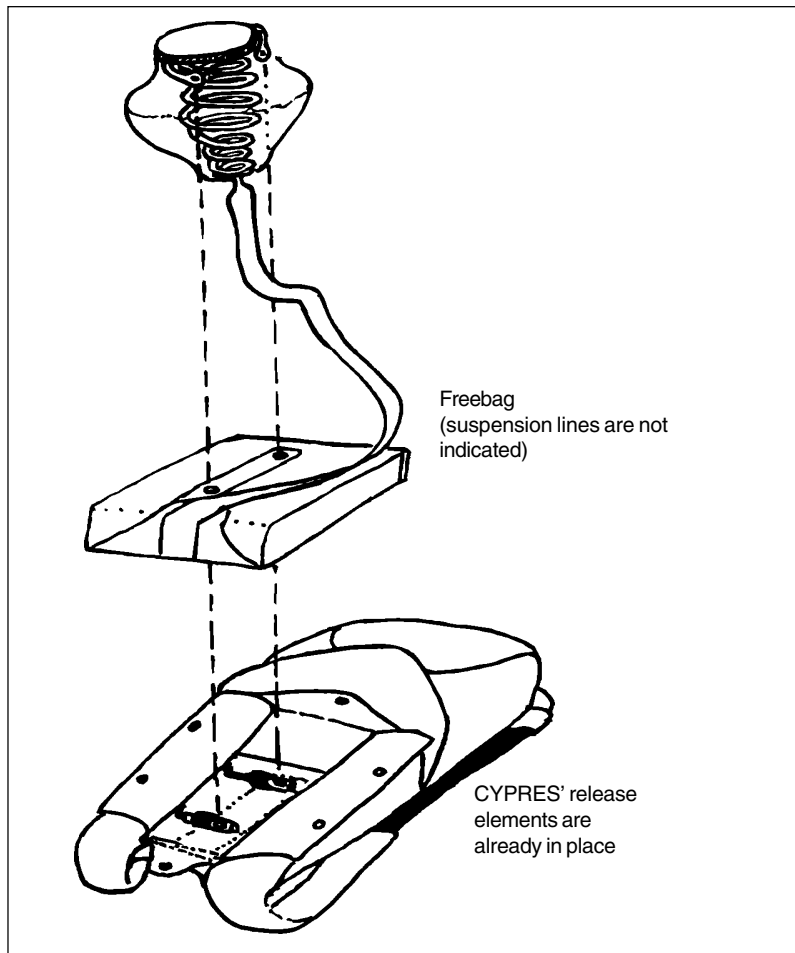

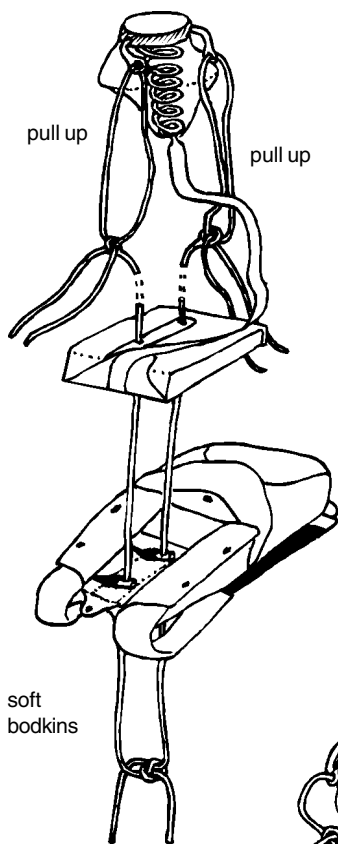

Altogether four packing lines are needed, two soft bodkins and two pull up cords. Both types will come together with your CYPRES. With the soft bodkins, pull the pull ups through the freebag, the release elements and the bottom of the container.

This is just a schematic drawing. In reality, the packing bands have to pass through the grommets of the closing flaps in their correct order after they have been pulled through the release elements and the freebag.



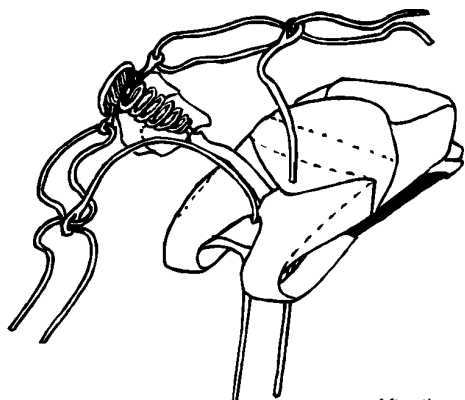

After the pull-ups have been pulled all the way through the bottom of the container, their ends can be tied together. Then with the rig placed at the edge of the packing table, it will be possible to step into the resulting loop with one foot, creating enough force to close the container with little effort.

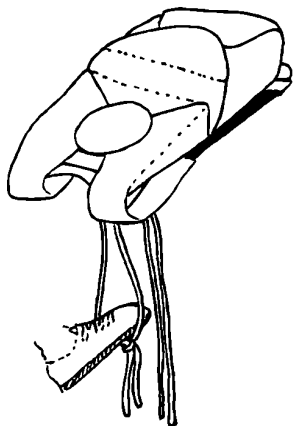

In order to facilitate introduction of the last ripcord pin, put a temporary pin into the loop first. Then, insert the ripcord pin into the loop underneath the temporary pin. After that, carefully extract the temporary pin.

In order to facilitate the packing procedure described on the last three pages, we recommend that you pass 2 conventional metal bodkins through the grommets at the bottom of the container, serving as a mechanical aid for the closing of the flaps.

The release elements in their elastic housings are mobile enough to allow temporary displacement while the bodkins stay inserted, and they will move back to their original position once the bodkins have been taken out. The bodkins can stay in place until all 4 flaps have been aligned properly.

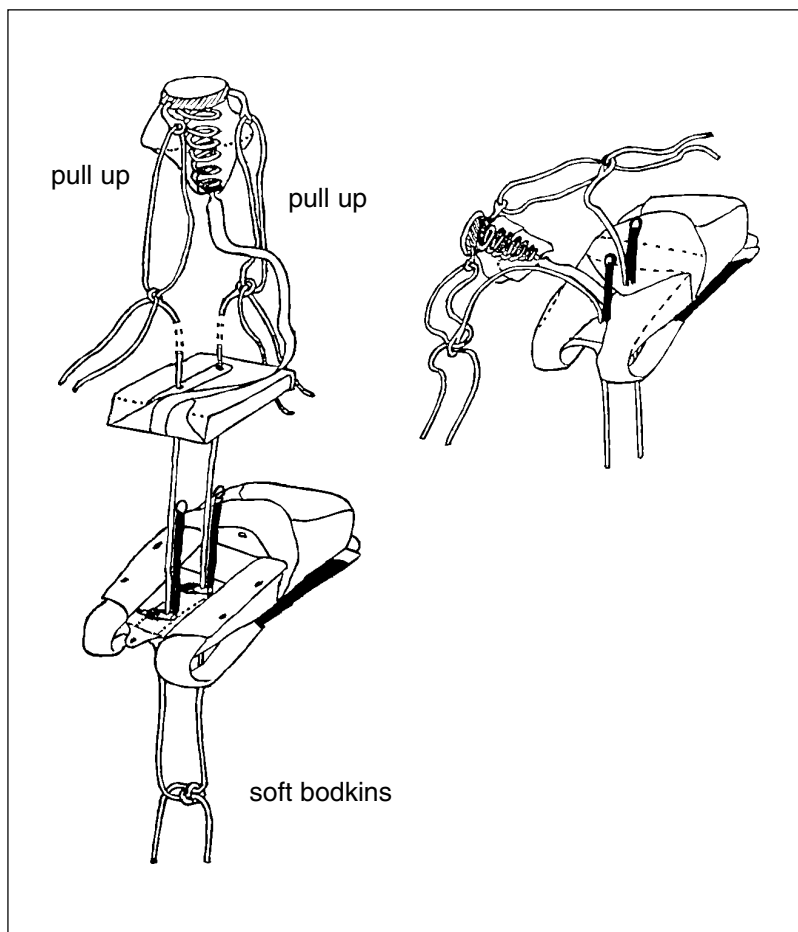

8.4.1 Additional notes to the Racer and Racer Elite

On Racer and Racer Elite systems in countries where US TSO standards apply, you must use the quick loop system in accordance with the manufacturer's instructions.

For both Running loops and quick loops however, you must use CYPRES polyamide loop material. Do not use silicone on quick loops.

Packing should then be done with soft bodkins, preferably by using 2 metal bodkins as described on page 45.

9. Abbreviated User's Guide

**! Activate CYPRES only when on the ground,
never in the aircraft !**

When **airfield and dropzone** are in **the same place**, always switch CYPRES on or off and back on again when

- it arrives at the dropzone by any means other than under an open canopy (e.g., by car or by walking back from landing away from the dropzone.)
- a flight to altitude, or a flight-plus-jump has taken longer than 1,5 hours.

If **airfield and dropzone** are at **different locations**:

- always switch CYPRES on at the airfield where your aircraft takes off, and change the reference altitude as appropriate.

If in doubt, switch it off. To continue jumping, switch it on again.

10. Changing the Container

It is no problem to remove CYPRES from your old container and assemble or install it into a new one (see chapter 3). If your new container is equipped with a CYPRES set up, your Rigger / Reserve Packer can easily assemble the CYPRES using the existing nylon pocket, cutter mounting(s) and cable housings. If a retrofit with the installation of a CYPRES set up is necessary, a new CYPRES set up kit can be obtainable from the nearest CYPRES Dealer or SSK.

If you intend to use your CYPRES on a new rig with a different number of pins (e.g. exchanging one-pin for two-pin systems, or vice versa) please exchange your field replaceable cutter to the correct system (1-pin or 2-pin) (see chapter 6.3). In case your CYPRES does not have the field replaceable style cutter, you may have your CYPRES Dealer arrange for the necessary alterations, or send it directly to SSK Industries, INC. (see chapter 6.4)

11. Regarding Air Travel

The luggage that you hand over at the airline's check-in counter often is not subject to X-ray examination.

Therefore, we suggest that when you travel with your CYPRES-equipped rig, check it in at the counter with other luggage. When doing so, make sure that CYPRES has been switched off.

However, it could still happen that your gear will be X-rayed during a luggage check, or because you have decided to take it on board as hand-carried luggage. The airline's security staff will then see on their X-ray machine screens a lot of wiring, battery, circuitry, etc. that could cause them to start asking questions.

In such a case, use the card below to explain what they are seeing.

12. Technical Data

Data applicable to all CYPRES:

Length, width, height of the processing unit	approx. 88 x 57 x 28.5mm
Length, width, height of the control unit	approx. 65 x 18 x 6.5mm
Length, diameter of the release unit	approx. 43 x 8.0mm
Cable length of the release unit	approx. 500mm
Storing temperature	+71° to -25° centigrade
Working temperature	+63° to -20° centigrade *
Maximum allowable humidity	up to 98 % rel. humidity
Altitude adjustment limits	±500m or ±1500 feet
Operating range above sea level	-500m to +8000m (-1600 feet to +26.000 feet)
Functioning period	14 hours
Battery life	approx. 500 jumps or approx. 2 years
Maintenance	4 and 8 years from date of manufacture ± 3 months
Total lifetime	12 years from date of manufacture + 3 months maximum

Special data for Expert CYPRES:

Cable length of control unit	approx. 670mm
Volume	approx. 165cm ³
Weight	approx. 262 gramm
Activation altitude	approx. 225m (approx. 750 feet)
Activation speed	≥ 35m/sec (78mph)

Special data for Student CYPRES:

Cable length of control unit	approx. 1000mm
Volume	approx. 170cm ³
Weight	approx. 279 gramm
Activation altitude	approx. 225m (approx. 750 feet)
Activation speed	≥ 13m/sec (29mph)

Special data for Tandem CYPRES:

Cable length of control unit	approx. 670mm
Volume	approx. 165cm ³
Weight	approx. 262 gramm
Activation altitude	approx. 580m (approx. 1900 feet)
Activation speed	≥ 35m/sec (78mph)

The above data apply to the civilian version.

* **These temperature limits do not mean the outside (ambient) temperatures but temperatures inside the unit.**

Therefore, these limits won't have any meaning until the unit itself has reached the temperature in question. In actual fact, the limits will rarely ever be reached because of the insulating properties of the nylon pocket and the recommended installation location.

13. Guarantee

Technical defects that show up during the first 12 months will be repaired by the manufacturer at no cost.

The manufacturer reserves the right to decide whether the unit will be repaired or replaced. Neither repair nor replacement will change the original period of guarantee (12 months).

When the unit is returned to the manufacturer, it must be packed in the original box, or an equivalent shipping package.

No claims will be accepted if the unit has been damaged or has been opened by an unauthorized individual, or if an unauthorized opening of the processing, release or control unit has been attempted. Also, no claim will be accepted if any energy supply other than the original battery provided by the manufacturer has been used in CYPRES.

14. Electromagnetic compatibility

Manufacturer's Certification:

We herewith certify that the automatic parachute activation device "CYPRES" (Cybernetic Parachute Release System) is free from electromagnetic interference in accordance with order no. 1045/1984 of Deutsche Bundespost.

Deutsche Bundespost was informed of the release of this system, and has been granted the right to check that these products conform to standard.

Airtec GmbH, Mittelstrasse 69, 33181 Wuennenberg, Germany

15. Disclaimer

In designing and manufacturing CYPRES, the aim of Airtec GmbH is that it should never cause an accidental canopy opening, but should open a reserve canopy at an appropriate altitude whenever necessary.

All investigations and experiments performed during the product's development, and all field tests accompanying trial and production phases have shown to date that CYPRES meets both requirements.

However, the occurrence of a malfunction cannot be excluded. We accept no responsibility for damages and consequences resulting from a malfunction.

16. Key Words

	page
Activation altitude	3,9,50
Activation altitude ranges	3,9
Air pressure measurements	5
Air travel	4
Altitude adjustments	21,22
Altitude difference	20-22,47
Base jumps	33
Battery	7,26-29
Battery cable	28,29
Battery plug	28
Battery voltage	18,26
Bodkins	39,40
Changing battery	26-29
Changing containers	48
Changing release elements	30
Coiling of cables	12,31
Components	4
Control unit	14-16
Design philosophy	3
Disclaimer	53
Disc	36,37
Displays	18,21,22,24
Electromagnetic compatibility	52
Electromagnetic shielding	33
Energy supply	7
Error	24
Error Display	24
Error Reports	8,24
Expert CYPRES	9
Fail-safe-principle	8
Freshwater	23
Function	3,5,6
Guarantee	51
Humidity	50
Installation	11-16
Jump pilot	32
Knots	36,37
Lid of Battery compartment	26,29
Loop	34,36-41
Loop material	34
Maintenance	25,31
Malfunction	53
Minimum altitude	3,9,32

	page
Off DZ landing	20,47
One-pin container	36
One-pin Pop Top	39
Operational safety	8
Packing	34-45
Packing list	56
Pilot chute	33
Processing unit	12
Push button	17,18
Range of altitude adjustments	21
Rate of descent	3,9,10
Release unit (EOS)	5,6,13
Removal	25
Repacking	34-45
Reserve loop	34-43
Running loop	40,41
Safety controls	49
Saltwater	23
Screws	26-29
Self-test	8,18
Service Center	31
Size	50
Student CYPRES	3,9
Summary	47
Switching off	19,20
Switching on	18-20
Switching-on procedure	18
Switching-on sequence	18
Tandem CYPRES	10
Technical data	50
Temperature range	50
Tensile strength	34
Trade Marks	57
Two-pin container	34,38
Two-pin Pop Top	40-45
User's Guide	47
Velcro	15
Volume	50
Water jumps	23
Weight	50
X-ray	49

17. Packing List

In addition to the CYPRES unit and the user's guide, the following items will be delivered:

	for a 1-pin CYPRES	for a 2-pin CYPRES
	1 pocket for processing unit 1 cable housing	1 pocket for processing unit 1 cable housing
1st bag:	1 elasticated housing 1 pocket for control unit 2 1-pin loops (in separate bag) 2 support discs 1 strip of velcro 1 pull up	2 elasticated housings 1 pocket for control unit 2 2-pin loops (in separate bag) 2 support discs 1 strip of velcro 1 running loop housing * 2 soft bodkins * 2 pull ups
2nd bag (for user/owner)	1 loop 1 pull up 1 support disc	1 2-pin loop 2 pull ups 2 support discs 2 soft bodkins *

Remark:

Some parts are delivered in larger quantities than necessary for installation. An additional loop and a surplus Running loop cord (2 in two pin CYPRES; plus 2 soft bodkins with two pin Pop Tops) should be stored in the nylon pocket next to CYPRES, so that they'll be at hand whenever necessary.

The second bag containing spare loop, pull-up, screwdriver etc. should be kept in your gear bag for the future.

* only to be used with 2-pin Pop Tops

Trade Marks

CYPRES is a trade mark of Airtec GmbH.

All rights reserved. No part of this publication may be reproduced or transmitted in any form or by any means, electronic or mechanical, including photocopying, microfilm, recording, or by any information storage and retrieval system, without permission in writing from Airtec GmbH. No patent liability will be accepted with regard to the use of information contained in this manual. This manual was compiled with due care. Airtec GmbH and all persons and institutions involved in the translation of this publication do not accept any liability for mistakes, omissions or for damages resulting eventually.

Airtec GmbH does not accept any liability for damages or problems arising from the use of components other than original Airtec products.

Copyright © 1991 by AIRTEC GmbH, Wuennenberg, Germany.

Barring changes for technical reasons.

As of 06 / 2001

Printed on chlorine-free bleached paper.

AIRTEC GmbH • Mittelstraße 69 33181 • Bad Wünnenberg • Germany
Tel.: +49 2953 / 9899-0 • Fax: +49 2953 / 1293